

Trucks for life
ISUZU

N-SERIES REWARD

Light-Duty Trucks GVW 5.2-9.5ton



Reliable Performance, Wide Model Range, and the Best Selection for Your Success

Excellent durability and reliable quality made in Japan to satisfy various user needs.
From in-city short-distance use to intercity long-distance transportation,
REWARD offers reliable performance to support your business.
Everyone will come to know ISUZU's quality and craftsmanship.



JAPAN QUALITY

Engineered &
Manufactured in
Japan

TESTED TOUCH

Durability &
Safety

PROVEN

Design,
Performance
& Function

High Standard, Reliable Strength

Tested in the toughest conditions to achieve reliable durability and strength. REWARD meets your needs with its toughness even in the scorching desert.



Durability

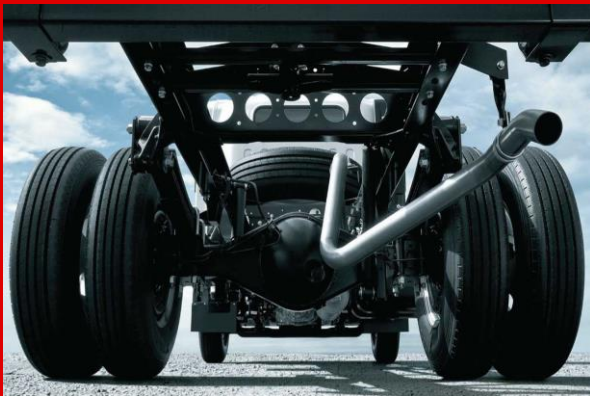

Robust Frame and Durable under Harsh Conditions

Frame width 850mm Fitted to the 6.5-ton class and above models.

Customers can utilize 850mm subframe body application, which is very common in Middle East Market. The strength of frame will increase durability and will provide longer lifetime for the vehicle.

Thicker dimensions of the frame makes it stronger when it is subjected to the load, making the truck more durable. Higher GAW, makes the weight distribution on the axle more flexible and durable.



Tough rigid axle suspension

Axles and suspensions are constructed not only to carry cargo, engine, and chassis, but also to provide better maneuverability, safety and comfort.

Rigid Axle Suspension

Safety

Active Safety

Multi-reflector halogen headlamps

Clear resin lenses and step reflectors provide outstanding illumination over a broad area to improve nighttime visibility and safety.



Front and rear drum brakes



Extra-large brakes improve braking performance

Passive Safety

Highly rigid cab



The highly rigid cab brings the highest level of collision safety to cab-over vehicles. Door waist areas are reinforced, and the frame is strengthened to maintain the integrity of the cab forming a protective cocoon that limits injury in the events of accident.

ELR 3-point system seatbelt



(Center seat: 2-point)
Effectively restrain and protect driver and passengers during a collision.

Reinforced door waist



Minimizes distortion in the shape of the cab in the event of accident.

ISUZU's Testing System that Supports High Durability

Endurance Reliability

Testing with various traveling patterns and driving situations in the special circuit that replicates the road conditions all over the world.

Environmental Responsiveness

Guarantees long-term operation in high temperature sandy environments.

Safety Performance

Pursues the performance of the vehicle's basic features such as braking performance and body safety structure.



World-renowned ISUZU Engine

The world-renowned ISUZU diesel engine with improved power, durability and fuel efficiency will lead your business to the next stage.

PRO (Electrical Control Engine)

High performance engine with high power output, fuel efficiency, and quiet operation.

4HG1 Direct-injection OHC intercooled turbo

- Displacement 4,570cc
- Max. Output 115PS/3,200rpm
- Max. Torque 304N•m (31.0kgf•m)

4HF1-N Direct injection, OHC intercooled turbo

- Displacement 4,334cc
- Max. Output 76 (103)
- Max. Torque 268N•m (27.0kgf•m)

4HK1-TC Direct-injection OHC intercooled turbo

- Displacement 5,193cc
- Max. Output 150PS/2,600rpm
- Max. Torque 402N•m (41.0kgf•m)

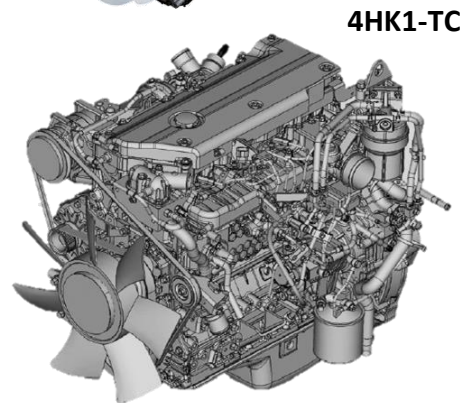
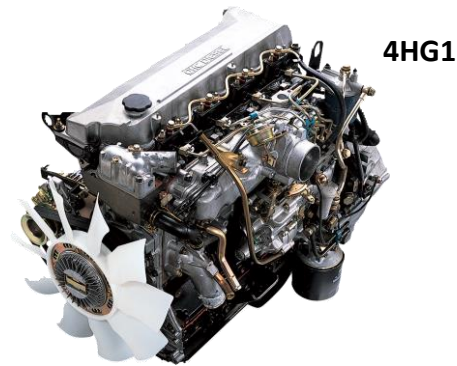

**Direct injection high pressure common rail system.
Simple structure with
higher durability.**

4JJ1-TC Direct Injection High Pressure Common Rail System – DOHC Intercooled Turbo

- Displacement 3,000cc
- Max. Output 131PS/2,600rpm
- Max. Torque 330N•m (34.0kgf•m)

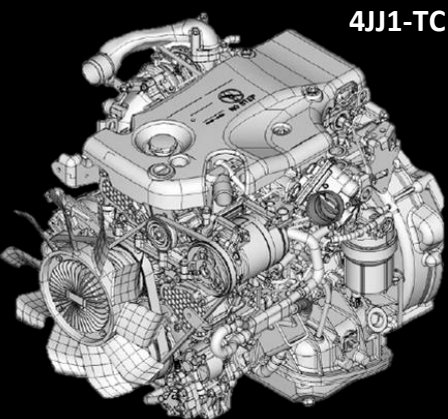

Common-rail injection system

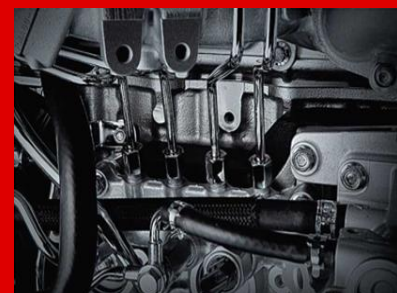

Electronic control precisely injects fuel at extremely high pressure in 1/1000 second units and determines optimal injection amounts, reducing NOx and particulate matter (PM). (4JJ1-TC)

16-Valve DOHC



Valve operation is accurately timed even at high rpm, increasing air intake and discharge from cylinders, thereby raising intake and exhaust efficiency. These optimal combustion conditions reduce PM and black smoke while raising fuel economy. (4JJ1-TC)



Ever improving ISUZU earns high evaluation around Middle East



Diversity

ISUZU continues to improve by collecting user needs from GCC countries and using them for future vehicles model development.

Customizability

Different kinds of vehicles specifications are lined up to match various body customizations.

Practicality

Thanks to its performance and durability, Isuzu maintains the number one position in the Middle East for almost a decade.

Reasons Why REWARD means High Quality



Engineering

Light-weight, compact, and high-power output engines that are precisely designed using the latest multi-dimensional CAD.

Quality Control

A well-established manufacturing structure which prevents defects from going through to the next process by setting multiple check points at each process.

Manufacturing

Distributed around the world, our production know-how, which we have cultivated over many years and has expanded our homogenized products and services globally.

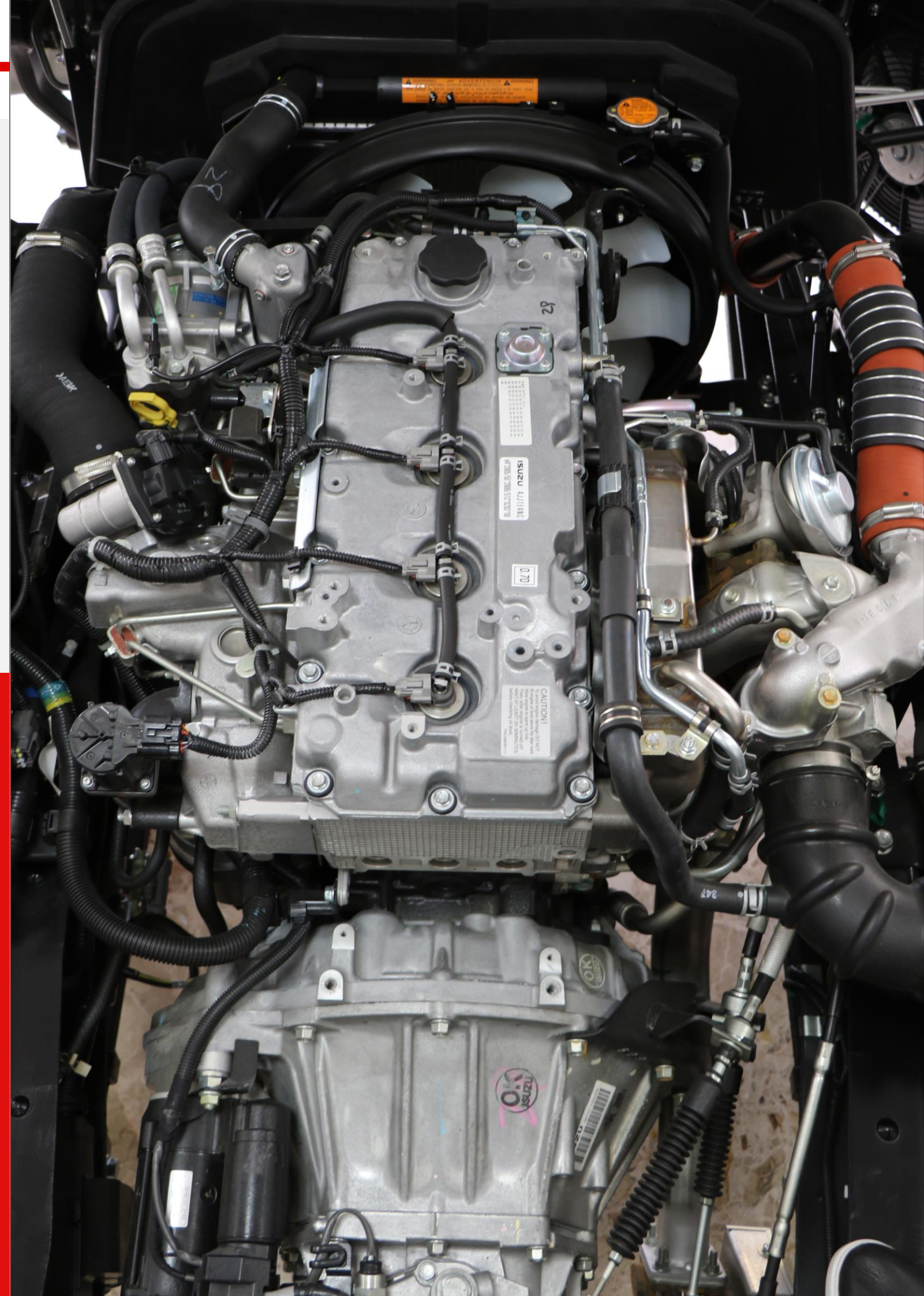

Meets Any Business Needs

Designed with functional beauty and customization to fulfill any job. With wide range of selections, you can choose the best model for your business.



LED Meters



Photo might vary from actual truck.

Meter panel graphics are totally renewed and incorporate ISO-compliant warning symbols. Meters are also easier to read, allowing drivers to confirm vehicle status at a glance. Moreover, LED lighting uses less electrical power, and lamps have a long service life.

More Space for DIN devices

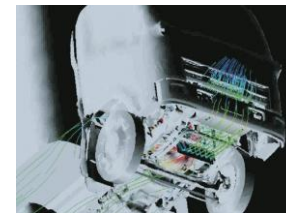

Photo might vary from actual truck.

Vehicles are being equipped with More devices that use DIN connectors, and there is plenty of room to neatly install Information terminals and audio equipment. Up to six DIN devices can be installed, Double than before.

Performance

Improved cooling performance



Computer analysis and actual testing of vehicles ensure that the cooling system is more than a match for the high performance of engines and emission treatment systems.

Manual transmission



Photo might vary from actual truck.

Powerful yet economical and easy to handle. Reliability and durability, you can count on.

Function

Excellent ingress/egress 90deg. door opening



The upright front pillars allow doors to open to 90-degree wide angle and provide a larger door opening for effortless cab access. Also, wider steps and floor contribute to easy ingress/egress.

Vertical outside handles



Vertical handles makes it easier to access tall vehicles. In addition, grips are designed to accommodate thick gloves. Thanks to entry grips and wide opening door angle, ISUZU achieved first place in easy entrance and exist.

NMR GVW 5,500kg

4JJ1-TC [5.5ton] 96kW(130PS)/2,800rpm 330N•m(34.0kgf•m)/1,600rpm	4HG1 [5.5ton] 115PS/3,200rpm 29.7kgf•m/1,600rpm
--	---



EXTERIOR COLORS



ARC WHITE
More colors available upon request.

NPR GVW 6,000 – 7,000kg



4JJ1-TC [6.5ton] 131PS/2,600rpm 330N•m(34.0kgf•m)/1,600rpm	4HG1 [6.5ton] 115PS/3,200rpm 29.7kgf•m/1,600rpm
--	---



4HK1-TC [7.0ton] 110kW(150PS)/2,600rpm 404N•m(41.0kgf•m)/1,600rpm	4HG1 [7.0ton] 115PS/3,200rpm 29.7kgf•m/1,600rpm
---	---

NQR GVW 8,000kg



4HK1-TC [8.0ton] 110kW(150PS)/2,600rpm 404N•m(41.0kgf•m)/1,600rpm	4HG1 [8.0ton] 115PS/3,200rpm 29.7kgf•m/1,600rpm
---	---

NMR/NPR Crew Cab GVW 5,500 – 6,000kg



4JJ1-TC [5.5ton] 96kW(130PS)/2,800rpm 330N•m(34.0kgf•m)/1,600rpm	4JJ1-TC [6.5ton] 131PS/2,600rpm 330N•m(34.0kgf•m)/1,600rpm
--	--

Factory complete vehicle applications

There are wide varieties of rear bodies, application-specific models and modifications to choose from, depending on the specialized needs of your business.

Three Drop Gate



Single cab (Wide)



Crew cab (Standard)

Dump



SUPPORT YOUR BUSINESS

Support System in Middle East Area

- Field Engineer** ■ Dispatched to the site when unforeseen problems arise. They identify the cause of the problem and solve it at the root so that malfunction never occurs again.
- Sales Engineer** ■ Survey and study customer needs and requests from all over the world and provide the best models and specifications for each market.
- Spare Parts** ■ Contribute to reduce down-time by supplying parts promptly using the dealer's network located in each country. Also, our depot is built in Dubai to meet the region needs and ensure parts availability.



NPR

Delivering profit to you



MAIN SPECIFICATIONS

Class	NPR				
Model	NPR85H221	NPR71H221	NPR71H261	NPR85K221	NPR71K221
Rear Tire	Dual	Dual	Dual	Dual	Dual
G.V.W. [Kg]	6.0t	6.0t	6.0t	6.0t	6.0t
Type	Chassis – Single Cab	Chassis – Single Cab	Cargo – Single Cab	Chassis – Single Cab	Chassis – Single Cab
Seating Capacity	3	3	3	3	3

ENGINE

Model	4JJ1-TC	4HG1	4HG1	4JJ1-TC	4HG1
Type	Direct Injection, DOHC, Diesel	Direct Injection, OHC, Diesel		Direct Injection, DOHC, Diesel	Direct Injection, OHC, Diesel
No. of cylinders	4	4	4	4	4
Displacement [cc]	3,000	4,570	4,570	3,000	4,570
Max. Output [PS/rpm]	131/2,600	115/3200	115/3200	131/2,600	115/3200
Max. Torque[kg.m/rpm]	34/1600	29.7/1,600	29.7/1,600	34/1600	29.7/1,600
Starter	24V-4.0 KW	24V-4.0 KW	24V-4.0 KW	24V-4.0 KW	24V-4.0 KW

MASS (kg)

Cab Chassis / Vehicle Mass	2,235	2,325	2,325	2,255	2,350

CHASSIS

Clutch	Type	Dry single plate				
	Size [mm]	300	300	300	300	300
Transmission	Type	MYY-5T 5Speed				
	Diameter [mm]	292	292	292	292	292
Final gear	Gear ratio	5.857	6.142	6.142	5.857	6.142
	Type	Oil Brake with VAC				
Brake	Parking	Mechanical Expanded Type at Rear of Transmission				
	Type	Power Steering				
Axle	Front	3100	3100	3100	3100	3100
	Rear	5000	5000	5000	5000	5000
Suspension		Leaf Spring				
Frame		Straight				
Tire		RIB 7.00R16-10				
Disc wheel		16 x 5.5F-115				
Fuel tank capacity liter		100L				

NPR					
NPR71K261	NPR85H421	NPR75F221	NPR75H221	NPR71F281	NPR75F281
Dual	Dual	Dual	Dual	Dual	Dual
6.0t	6.0t	7.0t	7.0t	7.0t	7.0t
Cargo- Single Cab	Chassis – Crew Cab	Chassis – Single Cab	Chassis – Single Cab	Dump – Single Cab	Dump – Single Cab
3	5	3	3	3	3

4HG1	4JJ1-TC	4HK1-TC	4HK1-TC	4HG1	4HK1-TC
Direct Injection, OHC, Diesel	Direct Injection, DOHC, Diesel	Direct Injection, OHC, Diesel			
4	4	4	4	4	4
4,570	3,000	5193	5193	4,570	5193
115/3200	131/2,600	150/2600	150/2600	115/2600	150/2600
29.7/1,600	34/1600	41.0/1600	41.0/1600	29.7/1600	41.0/1600
24V-4.0 KW	24V-4.0 KW	24V - 4.0kW	24V - 4.0kW	24V - 4.0kW	24V - 4.0kW

2,325	2,470	3420	2585	3265	3420
-------	-------	------	------	------	------

Dry single plate		Hydraulic Control, Dry Single Plate With Diaphragm Spring			
300	300	325	325	300	325
MYY-5T 5Speed	MYY-5T 5Speed	MYY-6T 6Speed	MYY-6T 6Speed	MYY-5T 5Speed	MYY-6T 6Speed
292	292	320	320	320	320
6.142	5.857	4.777	4.777	6.142	4.777
Oil Brake with VAC					
Mechanical Expanded Type at Rear of Transmission					
Power Steering					
3100	3100	Reverse Elliot, I-beam			
5000	5000	Full Floating			
Leaf Spring		Semi-elliptical Leaf Suspension, Hydraulic Double Acting Telescopic Shock Absorber			
Straight	Straight	Straight	Straight	Straight	Straight
RIB 7.00R16-10		7.50R16-10	7.50R16-10	7.50R16-10	7.50R16-10
16 X 5.5F-115	16 X 5.5F-115	16 X 6.00GS-127	16 X 6.00GS-127	16 X 6.00GS-127	16 X 6.00GS-127
100L	100L			100L	100L

NMR

Delivering profit to you



MAIN SPECIFICATIONS

Class	NMR			
Model	NMR85E221	NMR71E221	NMR71E261	NMR85H221
Rear Tire	Dual	Dual	Dual	Dual
G.V.W. [Kg]	5.5t	5.5t	5.5t	5.5t
Type	Chassis – Single Cab	Chassis – Single Cab	Cargo – Single Cab	Chassis – Single Cab
Seating Capacity	3	3	3	3

ENGINE

Model	4JJ1-TC	4HG1	4HG1	4JJ1-TC
Type	Direct Injection, DOHC, Diesel	Direct injection, OHC, Diesel		Direct Injection, DOHC, Diesel
No. of cylinders	4	4	4	4
Displacement [cc]	2,999	4,570	4,570	2,999
Max. Output [PS/rpm]	130/2,800	115/3200	115/3200	130/2,800
Max. Torque[kg.m/rpm]	34.0/1600	29.7/1600	29.7/1600	34.0/1600
Starter	24V-4.0kW	24V-4.0kW	24V-4.0kW	24V-4.0kW

MASS (kg)

Cab Chassis / Vehicle Mass	2000	2100	2375	2090
----------------------------	------	------	------	------

CHASSIS

Clutch	Type	Dry Single Plate			
	Size [mm]	300	300	300	300
Transmission	Type	MYY-5T 5Speed			
	Diameter [mm]	292	292	292	292
Final gear	Gear ratio	5.125	5.571 / 6.142	5.571 / 6.142	5.125
	Type	Oil Brake with VAC			
Brake	Parking	Center Brake			
	Type	Power Assist			
Axle	Front	F029	F029	F029	F029
	Rear	R050	R050	R050	R050
Suspension	Leaf Spring				
Frame	FR 740mm & RR 700mm	FR 740mm & RR 700mm	FR 740mm & RR 700mm	FR 740mm & RR 700mm	
Tire	Front & Rear	Rib 7.00r15-8			
Disc wheel	Front & Rear	5.5F-15-115	5.5F-15-115	5.5F-15-115	5.5F-15-115
Fuel tank capacity	liter	75L	75L	75L	100L

NMR			
NMR71H221	NMR85H261	NMR85H421	NMR85H461
Dual	Dual	Dual	Dual
5.5t	5.5t	5.5t	5.5t
Chassis – Single Cab	Cargo – Single Cab	Chassis – Crew Cab	Cargo – Crew Cab
3	3	5	5

4HG1	4JJ1-TC	4JJ1-TC	4JJ1-TC
Direct Injection, OHC, Diesel	Direct Injection, DOHC, Diesel		
4	4	4	4
4,570	2,999	2,999	2,999
115/3200	130/2,800	130/2,800	130/2,800
29.7/1600	34.0/1600	34.0/1600	34.0/1600
24V-4.0kW	24V-4.0kW	24V-4.0kW	24V-4.0kW

2190	2450	2295	2605
------	------	------	------

Dry Single Plate			
300	300	300	300
MYY-5T 5Speed	MYY-5T 5Speed	MYY-5T 5Speed	MYY-5T 5Speed
292	292	292	292
5.571 / 6.142	5.125	5.125	5.125
Oil Brake with VAC			
Center Brake			
Power Assist			
F029	F029	F029	F029
R050	R050	R050	R050
Leaf Spring			
FR 740mm & RR 700mm	FR 740mm & RR 700mm	FR 740mm & RR 700mm	FR 740mm & RR 700mm
Rib 7.00r15-8			
5.5F-15-115	5.5F-15-115	5.5F-15-115	5.5F-15-115
100L	100L	75L	75L

NQR & NKR

Delivering
profit to you



MAIN SPECIFICATIONS

Class	NQR			
Model	NQR71H221	NQR75H221	NQR71K221	NQR75K221
Rear Tire	Dual	Dual	Dual	Dual
G.V.W. [Kg]	8.0t	8.0t	8.0t	8.0t
Type	Chassis - Single	Chassis - Single	Chassis - Single	Chassis - Single
Seating Capacity	3	3	3	3

ENGINE

Model	4HG1	4HK1-TC	4HG1	4HK1-TC
Type	Direct Injection, OHC, Diesel			
No. of cylinders	4	4	4	4
Displacement [cc]	4,570	5193	4,570	5193
Max. Output [PS/rpm]	115/3200	150/2600	115/3200	150/2600
Max. Torque[kg m/rpm]	29.7/1600	41.0/1600	29.7/1600	41.0/1600
Starter	24V - 4.0kW	24V - 4.0kW	24V - 4.0kW	24V - 4.0kW

MASS (kg)

Cab Chassis / Vehicle Mass	2455	2585	2480	2610

CHASSIS

Clutch	Type	Hydraulic control, dry single plate with diaphragm spring			
	Size [mm]	300	325	300	325
Transmission	Type	MYY-5T 5Speed	MYY-6T 6speed	MYY-5T 5Speed	MYY-6T 6speed
	Diameter [mm]	320	320	320	320
Final gear	Gear ratio	6.833	4.777	6.833	4.777
	Type	Oil Brake with VAC			
Brake	Parking	Mechanical expanded type at rear of transmission			
	Type	Power steering			
Axle	Front	Reverse Elliot, I-beam			
	Rear	Full floating			
Suspension		Semi-elliptical leaf suspension, hydraulic double acting telescopic shock absorber			
Frame		Straight			
Tire	Front & Rear	7.50R16-14			
Disc wheel	Front & Rear	16 x 6.00GS-127			
Fuel tank capacity	liter	100L			

NQR		NKR	
NQR71L221	NQR75L221	NKR66E2 - 5HXY2	NKR66LL - 5HXY2
Dual	Dual	Dual	Dual
8.0t	8.0t	5,500	5,500
Chassis - Single	Chassis - Single	Single Cab	Single Cab
3	3	2	2

4HG1	4HK1-TC	4HF1-N	4HF1-N
Direct Injection, OHC, Diesel	Direct Injection, DOHC, Diesel	Direct Injection, OHC, Diesel	
4	4	4	4
4,570	5193	4,334	4,334
115/3200	150/2600	76 (103)	76 (103)
29.7/1600	41.0/1600	268 (27)	268 (27)
24V - 4.0kW	24V - 4.0kW	Check OPT	Check OPT

2500	2630	TBC	TBC
------	------	-----	-----

Hydraulic control, dry single plate with diaphragm spring		Dry single plate	
300	325	300	300
MYY-5T 5Speed	MYY-6T 6speed	MYY-5T 5Speed	MYY-5T 5Speed
320	320		
6.833	4.777	6.142	6.142
Oil Brake with VAC		VAC	
Mechanical expanded type at rear of transmission		Oil Brake with VAC	
Power steering		Center Brake	
Reverse Elliot, I-beam		2,500	2,500
Full floating		4,000	4,000
Semi-elliptical leaf suspension, hydraulic double acting telescopic shock absorber		MLS	
Straight		700	700
7.50R16-14		7.00R-16-10	
16 x 6.00GS-127		Drum 300x75 2L	
100L		75L	100L

Dimensions

Unit:mm

MODEL	NPR85 H221	NPR71 H221	NPR71 H261	NPR85 K221	NPR71 K221	NPR71 K261	NPR85 H421	NPR75 H221	NPR71 F281	NPR75 F281	NKR66E2 -5HXY2	NKR66LL -5HXY2	NQR71 H221
REAR TIRE	Dual	Dual	Dual	Dual	Dual	Dual	Dual	Dual	Dual	Dual	Dual	Dual	Dual
TYPE	Chassis	Chassis	Cargo	Chassis	Chassis	Cargo	Chassis	Chassis	Dump	Dump	Single	Single	Chassis
OAL	6,100	5985	6125	6750	6635	6800	6100	5985	5115	5115	TBC	TBC	5985
OW	2040	2040	2040	2040	2040	2040	2040	2040	2040	2040	TBC	TBC	2040
WB	3395	3365	3365	3845	3815	3815	3395	3365	2765	2765	TBC	TBC	3365
AW	1680	1680	1680	1680	1680	1680	1680	1680	1680	1680	TBC	TBC	1680
BW	1920	2085	2085	1920	2085	2085	1920	2125	2125	2125	TBC	TBC	1650
CW	1485	1650	1650	1485	1650	1650	1485	1650	1650	1650	TBC	TBC	1650
FOH	1110	1110	1110	1110	1110	1110	1110	1110	1110	1110	TBC	TBC	1110
ROH	1595	1510	1650	1795	1710	1875	1595	1510	1240	1240	TBC	TBC	1510
CA	2820	2790	2790	3270	3240	3240	1745	2790	-	-	TBC	TBC	2790
CE	4415	4300	4415	5065	4950	5115	3340	4300	-	-	TBC	TBC	4300
OH	2235	2255	2255	2235	2255	2255	2235	2265	2340	2340	TBC	TBC	2275

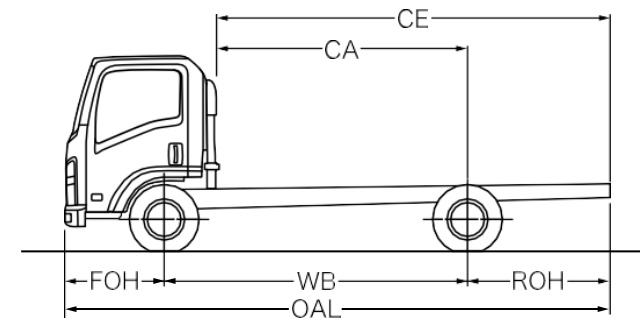
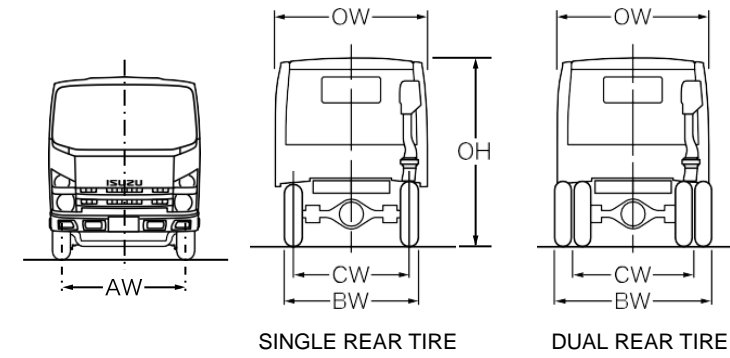

NM / NP / NQ / NK

The photo doesn't reflect the actual dimensions of all the models

Unit:mm

MODEL	NQR75 H221	NQR71 K221	NQR75 K221	NQR71 L221	NQR75 L221	NMR85 E221	NMR71 E221	NMR71 E261	NMR85 H221	NMR71 H221	NMR85 H261	NMR85 H421	NMR85 H461
REAR TIRE	Dual	Dual	Dual	Dual	Dual	Dual	Dual	Dual	Dual	Dual	Dual	Dual	Dual
TYPE	Chassis	Chassis	Chassis	Chassis	Chassis	Chassis	Chassis	Cargo	Chassis	Chassis	Cargo	Chassis	Cargo
OAL	5985	6635	6635	7355	7355	4730	4730	4805	6030	6030	6110	6030	6110
OW	2040	2040	2040	2040	2040	1860	1860	1890	1860	1860	1890	1860	1890
WB	3365	3815	3815	4175	4175	2475	2475	2475	3345	3345	3345	3345	3345
AW	1680	1680	1680	1680	1680	1475	1475	1475	1475	1475	1475	1475	1475
BW	1650	1650	1650	1650	1650	1860	1860	1860	1860	1860	1860	1860	1860
CW	1650	1650	1650	1650	1650	1425	1425	1425	1425	1425	1425	1425	1425
FOH	1110	1110	1110	1110	1110	1110	1110	1110	1110	1110	1110	1110	1110
ROH	1710	2070	1510	1710	2070	1145	1145	1220	1575	1575	1655	1575	1655
CA	3240	3600	2790	3240	3600	1900	1900	1900	2770	2770	2770	1710	1710
CE	4950	5670	4300	4950	5670	3045	3045	3120	4345	4345	4425	3285	3365
OH	2275	2275	2275	2275	2275	2150	2150	2150	2160	2160	2160	2160	2160

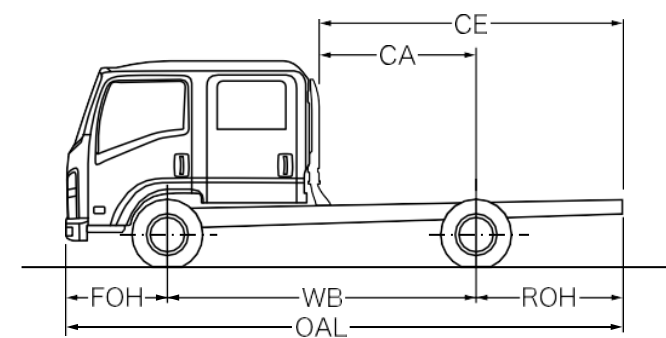
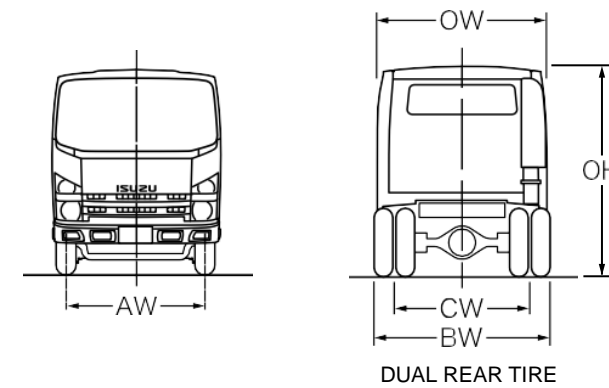

NM / NP Crew cab

The photo doesn't reflect the actual dimensions of all the models

● : Standard equipment ◎ : Option equipment -- : Not Available

OPTIONS

MODEL	NQR71 H221	NQR75 H221	NQR71 K221	NQR75 K221
-------	---------------	---------------	---------------	---------------

INTERIOR

Radio -Am/Fm Stereo, seek/Scan, cd, Etc.	●	●	●	●
Seat Belt (Driver / Co-driver : With ELR 3-points, Center : 2-points)	●	●	●	●
Ashtray (Driver)	●	●	●	●
Heater / Defroster	●	●	●	●
Air Conditioner	●	●	●	●
Tachometer	●	●	●	●
Speedometer (Km / H)	●	●	●	●
Power Window / Power Door Locks	●	●	●	●
Power Steering	●	●	●	●
Tilt And Telescopic Steering	●	●	●	●
Roof Header Tray (Driver)	●	●	●	●
Cup Holder	●	●	●	●
Coat Hook	●	●	●	●
Assist Grip	●	●	●	●
Sunvisor (Driver / Co-driver)	●	●	●	●

EXTERIOR

Radiator grille (Gray)	●	●	●	●
Bumper (Gray)	●	●	●	●
Front fog lamp	●	●	●	●

FUNCTION

Pre-fuel Filter	●	●	●	●
Fuel Tank Lock	●	●	●	●
Wiper-intermittent Type	●	●	●	●
Exhaust Brake	●	●	●	●
Horn-dual Tone	●	●	●	●
PTO (Power-take-off)	●	●	●	●
Reversing Warning Buzzer	●	●	●	●
Pre-Air Cleaner	●	●	●	●
Power Clutch	●	●	●	●

NQR71 L221	NQR75 L221	NKR66E2- 5HXY2	NKR66LL- 5HXY2
---------------	---------------	-------------------	-------------------

●	●	●	●
●	●	●	●
●	●	●	●
●	●	●	●
●	●	--	--
●	●	●	●
●	●	●	●
●	●	--	--
●	●	●	●
●	●	--	--
●	●	--	--
●	●	--	--
●	●	●	●

(※) check with your local DLR "Radio system"

●	●	--	--
●	●	--	--
●	●	--	--

●	●	--	--
●	●	--	--
●	●	--	--
●	●	--	--
●	●	●	●
●	●	●	--
●	●	●	●
●	●	--	--
●	●	--	--



Trucks for life
ISUZU



ISUZU MOTORS INTERNATIONAL FZE
S50909 Jebel Ali Free Zone, P.O.Box 263188
Dubai, United Arab Emirates

ISUZU MOTORS LIMITED reserves the right to change specifications and equipment without notice.
Details of specifications and equipment are also subject to change to meet local conditions and government requirements.
Please inquire at your local ISUZU representative for more complete details of any such changes that may be required.